

NESTING TABLE

assembly instructions

STEP 1

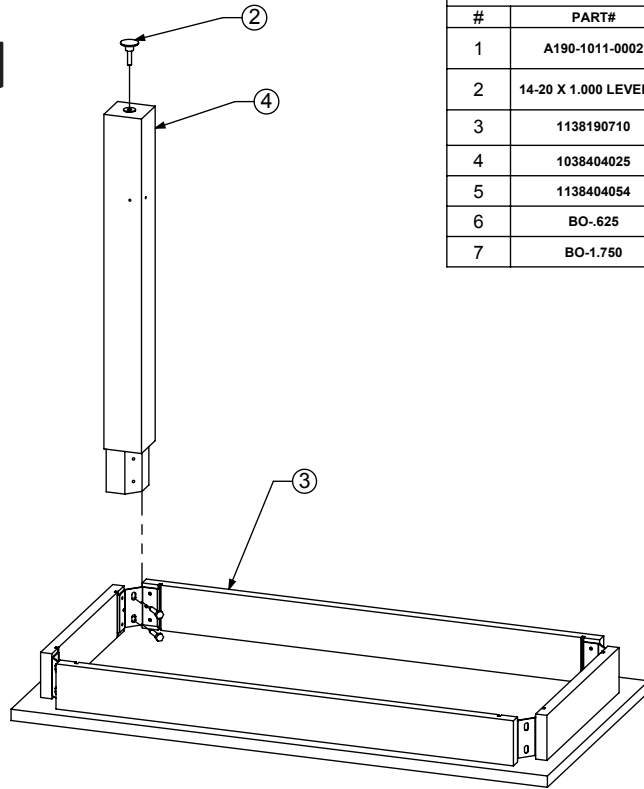

BOM			
#	PART#	QTY.	TITLE
1	A190-1011-0002	8	1/4" X 1.250 LAG SCREW
2	14-20 X 1.000 LEVELER	4	LEG LEVELER
3	1138190710	1	Table Top SubAssm
4	1038404025	4	NESTING TABLE LEG
5	1138404054	2	NESTING TABLE SIDE SKIRT
6	BO-.625	4	#8x0.625 WOOD SCREW
7	BO-1.750	2	#8x1.750 WOOD SCREW

STEP 2

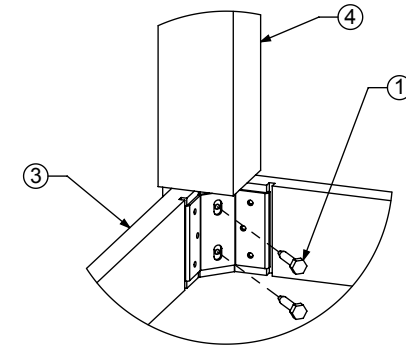

DETAIL B
SCALE 1 : 6

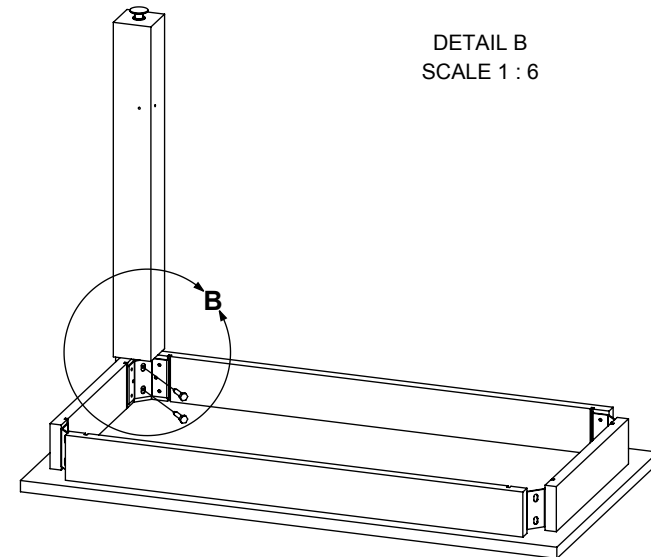

- THREAD LEG LEVELER (ITEM 2) INTO LEG (ITEM 4).
- PLACE LEG ON UNDERSIDE OF TABLE TOP ASSEMBLY, AGAINST STEEL BRACE.

- ATTACH LEG TO TABLE USING (2) 1/4" X 1.25" LAG SCREWS (ITEM 1)
- REPEAT (3 TIMES) FOR EACH TABLE

OPTIONAL SIDE SKIRT INSTALLATION

STEP 3

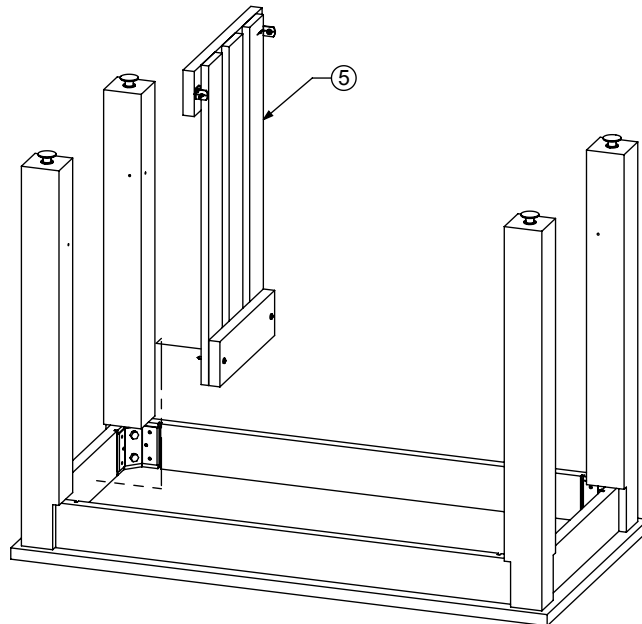

STEP 4

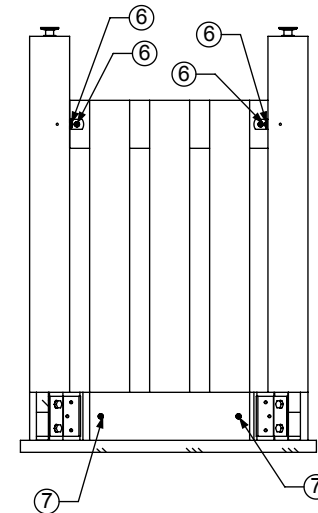

- PLACE SIDE SKIRT (ITEM 5) ON INSIDE OF SKIRT ON TABLE TOP ASSEMBLY.

- ATTACH TOP OF SIDE SKIRT TO TABLE TOP USING (2) #8 X 1.75" WOOD SCREWS (ITEM 7). USE PILOT HOLES FOR SCREW LOCATION.
- ATTACH BOTTOM OF SIDE SKIRT TO TABLE LEGS USING (2) L-BRACKETS AND (4) #8 X .625" SCREWS (ITEM 6). USE PILOT HOLES FOR SCREW LOCATION IN LEGS AND BOTTOM OF SIDE SKIRT
- REPEAT FOR OTHER SKIRT SIDE.

BOM			
#	PART#	QTY.	TITLE
1	A190-1011-0002	8	1/4" X 1.250 LAG SCREW
2	14-20 X 1.000 LEVELER	4	LEG LEVELER
3	1138190710	1	Table Top SubAssm
4	1038404025	4	NESTING TABLE LEG
5	1138404054	2	NESTING TABLE SIDE SKIRT
6	BO-.625	4	#8x0.625 WOOD SCREW
7	BO-1.750	2	#8x1.750 WOOD SCREW